

Binks

Quick Cleaner

Product Overview





Instantly lower solvent
use on both manual and
automatic systems

Quick Cleaner

- Reduces solvent use for existing automated paint lines
- Flush time reductions possible with robot re-programming
- Both solvent and time reductions for manual applications
- Promotes being more Eco friendly by reducing VOC's
- Creates a scrubbing cleaning action in hoses & pipes



HD-QCH-500



Reduced Solvent Consumption (~30-50%)



Reduced Cleaning Time (~20%)



Cleaner Fluid Passage

Robot/Auto Gun Installation

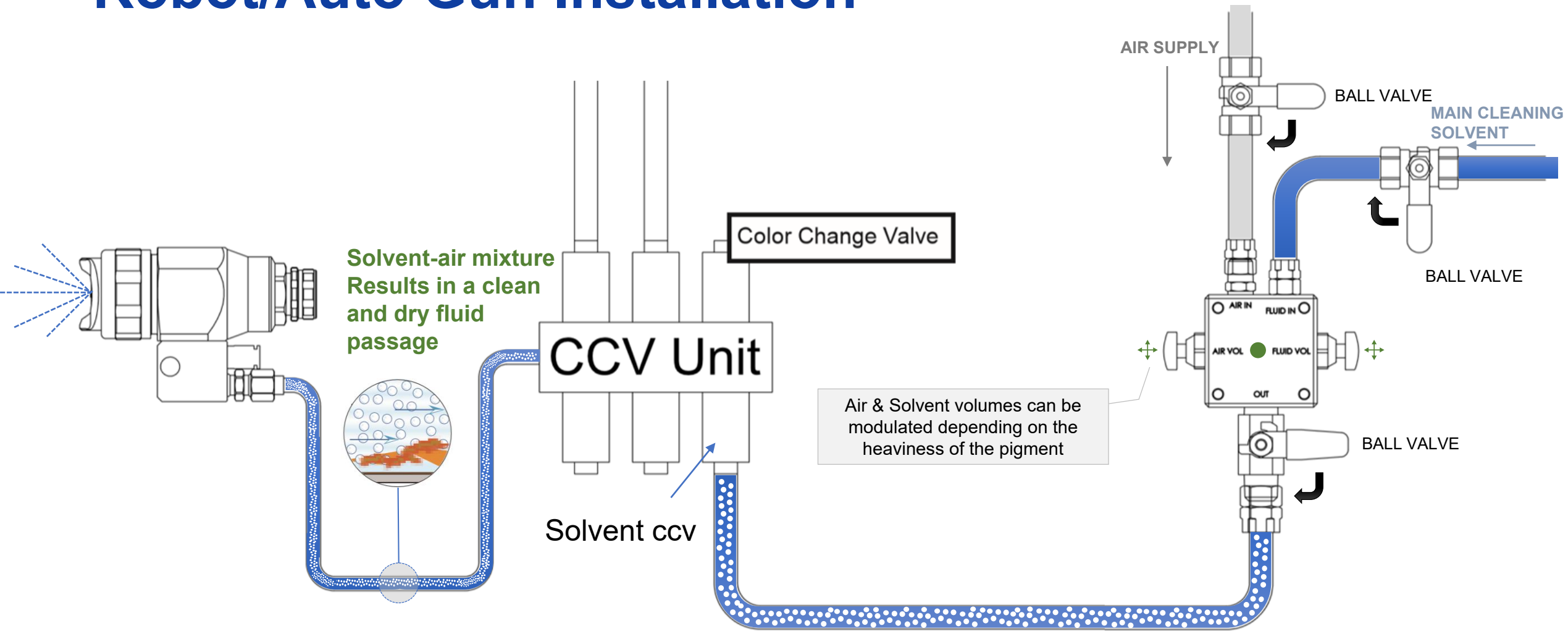

Manual Installation Example

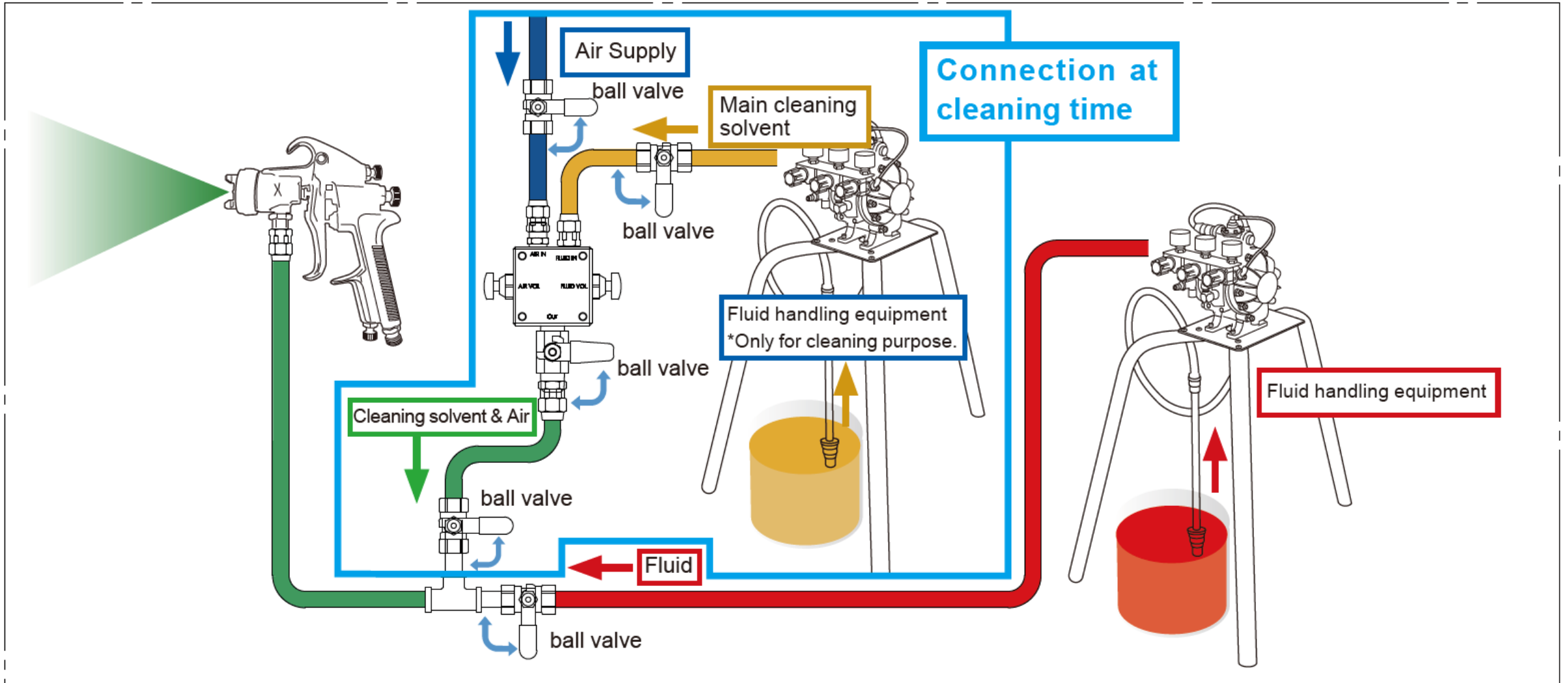

Scrubbing Cleaning Action

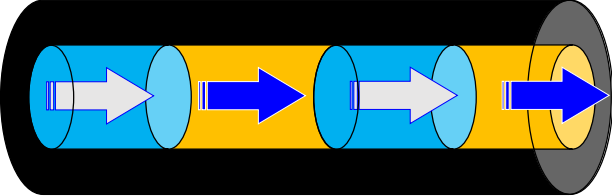

'Solvent-Air' flushing sequences

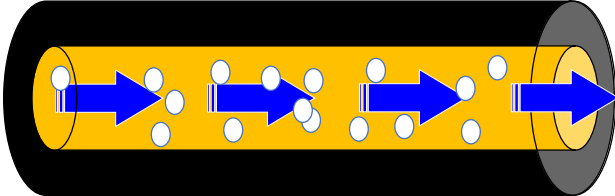

'Solvent with Air bubbles' flushing sequences

BEFORE

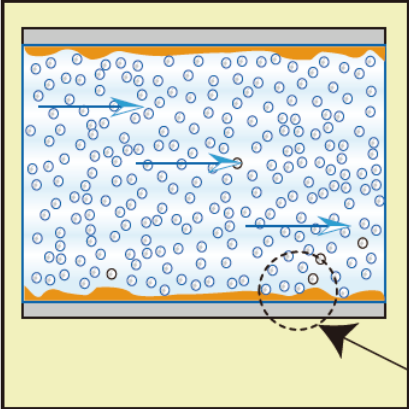
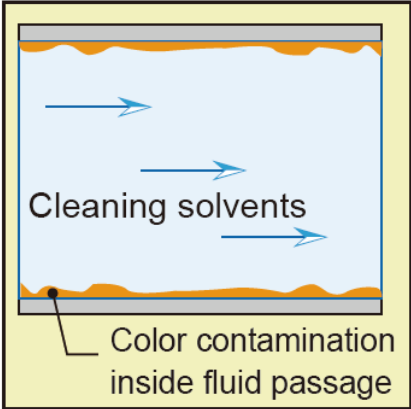

AFTER

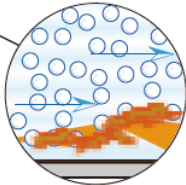

DIFFERENCE

Real Customer Savings

SOLVENT CONSUMPTION REDUCTION / CALCULATION*

Solvent Used/Cleaning Cycle	700 cc
No. of Cleaning Cycles/Hour	7
Solvent Consumed/Hour	4900 cc
Solvent Consumed/Day	117.6 litres 31.1 gallons

Solvent Used/Cleaning Cycle	490 cc
No. of Cleaning Cycles/Hour	7
Solvent Consumed/Hour	3430 cc
Solvent Consumed/Day	82.3 litres 21.7 gallons

Reduced Solvent Consumption (~30%)

Solvent Saving per day (~35 litres / 9.4 Gallons)



~ 1€/lt- 2 €/lt
~ 1\$/lt- 2 \$/lt

* Assuming 24 hour operation

30 litres x 2 €/lt -> 45 €/day x 22 working days -> 990 € Savings per month.

ROI -> 1 – 2 months

Advantages

- Full SS construction
- Easy to fit for instant savings on VOC reduction projects
- 100% mechanical, limited wearing parts, very low maintenance
- Comes complete with air and solvent one-way check valves
- Good cleaning of hose inner wall and scale formation.
- Best suited for high pigmentation color.
- Air and solvent volume can be adjusted using screw valve on either side.
- Ball valve included on output
- Easy to mount
- Engraved markings for easy identification

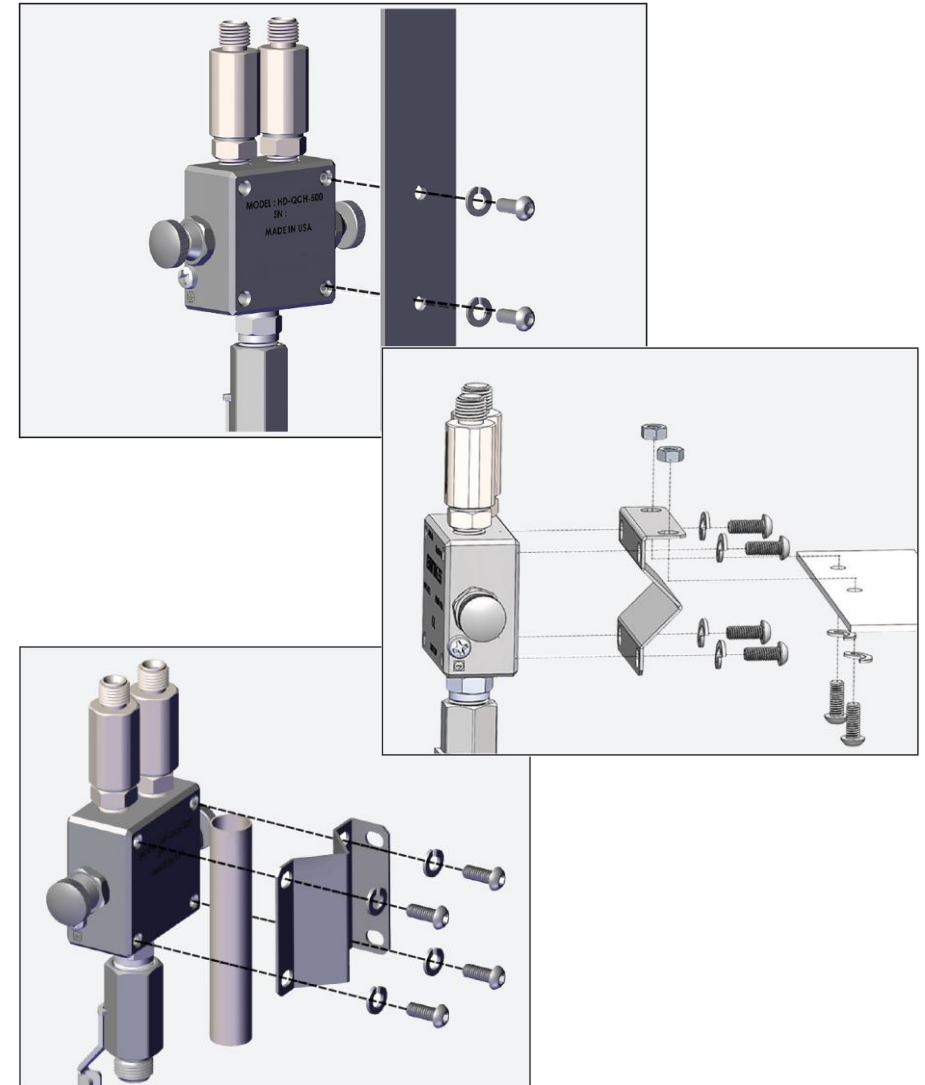

Car Stock Demo Procedure

1. Measure existing solvent flush volumes in the line
2. Adjust pressure gauges of solvent & air lines
3. Minimize pressure differential between air and solvent pressures (for equal mix)
4. Start with fully open volumetric adjustment knobs on the Quick Cleaner
 - Clockwise = flow rate decrease
 - Anti-clockwise = flow rate increase
5. Use clear tubing on the outlet (even for a short length) to visually see the setting effect
6. Aim for lots of air bubbles in the solvent but not too foamy
7. Monitor the flush rates with different settings
8. Use darkest color to white or vice versa to see cleaning efficiency
9. Set it for the toughest color like green, orange, blue, metallic or high pigment color
10. Observe the savings and calculate the ROI

Thank you



Binks

Binks